

PowerCache® – L (470 kVA / 460 kWh) Datasheet

PowerCache® – M: Grid-in-a-Box

PowerCache is a utility-grade grid in a box. It enables operators of ultra-fast EV charging, commercial or industrial sites, microgrids and communities to provide an unconstrained power user experience on a constrained network. This versatile power system combines a robust, ultra-rapid-response power converter/controller and a high-performance battery with intelligent microgrid control. PowerCache is expandable and integrates with other systems on-site. It can participate in ancillary services markets.



ChargeCach-M for illustration only –
 ChargeCache-L (this datasheet) is wider

System Performance	
Nominal frequency and voltage	47Hz ... 53Hz, 415V or 400V +10%/-6%
Grid connection	3-phase+N, YNd transformer-coupled
Active and reactive power rating	$S_{Nom} = 470$ kVA - 4-quadrant P&Q, symmetrical apparent power available
Inverter maximum continuous load	3-phase: $S_{Nom} = 470$ kVA Single phase: $S_{Nom}/\sqrt{3}$ (other phases not loaded)
Permissible phase load imbalance	Unlimited within the rating per phase +/-
Inverter base electrical function	<ul style="list-style-type: none"> • Current source (on-grid) • Virtual synchronous machine (on- & off-grid, various load-sharing modes)
Harmonics	Compliant with AS4777.2
Reaction time ext signal / step load	<50 ms / <50 ms
Primary frequency control step response – rise time / settling time	User definable via generator time constant and frequency PID control, typically: 150 ms / 1500 ms
System overload capability	400% instantaneous, 200% for 2 s, 110% for 1 minute in 10 minutes
AC protection	Over/under current/voltage/frequency, two locations (inter-tie), various timings, RoCoF, VVS, negative sequence voltage, sync-checks, active and passive 3-phase and single-phase anti-islanding to AS4777, insulation monitoring
Application-level protections	Over/under SoC, sustained overvoltage, protection consistency checks, application alarms, safe states after system transition failures, etc, via the PaDECS® control system
DC protection	Insulation monitoring, overcurrent/voltage, Battery OEM protections
System AC-AC round trip efficiency	>84% including HVAC-losses >89% excluding HVAC-losses for a typical application scenario.

Battery Performance	
Rated total DC energy	> 460 kWh
Battery chemistry	NMC cathode, $\text{LiNi}_x\text{Mn}_y\text{Co}_z\text{O}_2$, pouch cell structure
Indicative battery cycle life / full cycle equivalents (FCE)	4,000 FCE at 90% DoD to 70% capacity retention; or 5,000 FCE at 80% DoD to 70% capacity retention
Battery calendar life	>13 years
Battery Protection	Cell-, rack- and system-level supervision, control and protection of current, voltage, power, SoC, SoH, temperature, imbalances in these quantities, insulation and component failures

Interface	
Web-API	Web-API via VPN
SCADA	Modbus TCP or discrete hardwired alarms and E-Stop
System HMI	GUI web-application via VPN
Local data Historian Client	Logging all system features, parameters, modes and actuals, access via VPN
Cloud-Client GUI and API	Cloud-Client GUI and API via the PaDECS® portfolio & market cloud aggregator service (SaaS)
Direct component Web-HMIs	Engineering access to protection relay, inverter, battery and auxiliaries

Mechanical	
Inverter System Module	
Fire mitigation	Smoke & heat detection
Cabinet cooling	Forced air cooling, air inlet: large impeller & pleat filter assembly, outlet: roof frame – noise optimised
Cabinet structure	Single-walled, lined with heat & noise protective foam
Dimensions	Height x Width x Depth = 2,350 mm x 1,840 mm x 1,920 mm
Weight	3,700 kg
Battery System Module	
Fire mitigation	Novec® gaseous fire suppression system with detector tube
Battery Enclosure Cooling	HVAC split cycle air cooled via door coolers, internal temp: 19° C ... 27° C, heaters, humidity control, integrated controlled air circulation
Cabinet structure:	Double-walled
Dimensions	Height x Width x Depth = 2,350 mm x 1,860 mm x 1,920 mm
Weight	5,100 kg (with battery modules installed), 1,900 kg (without modules / for transport)

Environmental	
Humidity	5% to 100% outside 5% to 95%, non-condensing inside cabinet
Altitude	Up to 1,000 m without derating
Inverter System Module	
Operating ambient temperature	0 – 40° C without derating, -20 – 50° C max
Noise (max. @ 1 m distance)	<65 dBA
IP Rating	IP54 outdoor cabinet
Battery System Module	
Operating ambient temperature	0 – 45° C (sustained)
Noise (max. @ 1 m distance)	<60 dBA, excluding when compressor operating. <70 dBA, when HVAC compressor operating
IP Rating	IP55 outdoor cabinet

Compliance	
AS/NZS 4777.2:2020	The inverter/filter assembly is compliant (Model: Vacon NXA04605) is AS4777.2 certified (Certificate No.: SAA192864). ChargeCache-L operates two certified assemblies in parallel.
AS 5139	Safety of battery systems for use with power conversion equipment
IEC 61000 (Part 3)	EMC emission limits
EN 61800	EMC requirements for adjustable speed electrical power drive systems
AS 3000	Electrical wiring rules
AS 3800	Selection of cables for alternating voltages up to 0.6 / 1 kV
EN 61558-2-1	Safety of power transformers

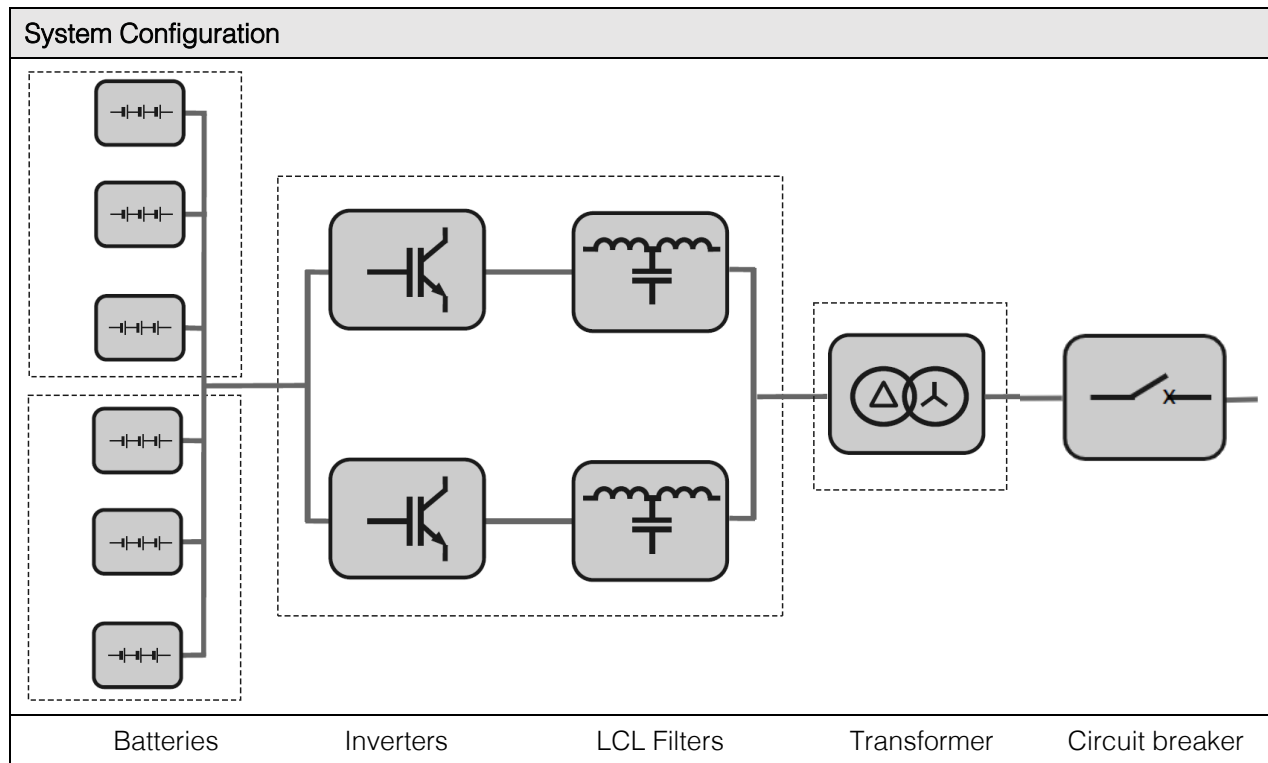

Contact

Power Technology Engineered Solutions Pty Ltd
 Unit 18/25 Cook Road Mitcham 3132, Australia
 power-tec.com.au